

SPECIFICATIONS FOR STANDARD DETAILS LS-2 & LS-3

1. STREET TREES SHALL BE PLANTED IN THE PUBLIC SERVICE EASEMENT (P.S.E.).
2. A STREET TREE PERMIT SHALL BE OBTAINED PRIOR TO PLANTING OR REMOVING ANY STREET TREE (CITY CODE SECTION 26.7).
3. AN ENCROACHMENT PERMIT IS REQUIRED TO INSTALL ANY PERMANENT COVERING SUCH AS CONCRETE, OVER THE CITY PARKWAY STRIP. IT SHOULD BE NOTED THAT IF ANY REPAIRS ON UNDERGROUND UTILITIES IN THE PARKWAY STRIP ARE REQUIRED, SUCH PERMANENT COVERING WILL BE REMOVED IN A PROFESSIONAL MANNER, BUT NOT REPLACED.
4. STREET TREES SHALL BE A MINIMUM SIZE OF FIFTEEN (15) GALLON CONTAINER.
5. THE TREE SPECIES PLANTED SHALL BE DESIGNATED SPECIES PER THE MASTER STREET TREE PLANTING PLAN (CITY CODE SECTION 26.5-1). THE PARKS AND RECREATION COMMISSION MAY MAKE EXCEPTIONS BASED UPON WRITTEN REQUEST TO PLANT A DIFFERENT SPECIES.
6. STREET TREES SHALL BE SPACED THIRTY (30) FEET APART UNLESS SPECIAL CIRCUMSTANCES DICTATE DIFFERENT SPACING.
7. STREET TREES SHALL BE SPACED AT LEAST FIFTY (50) FEET FROM STOP SIGNS and TRAFFIC SIGNALS, TEN (10) FEET FROM SEWER LATERALS AND STREET LIGHTS, AND FIVE (5) FEET FROM WATER LATERALS, GAS LATERALS, FIRE HYDRANTS, DRIVEWAY APRONS, AND TELEPHONE/CABLE/ELECTRICAL JUNCTION BOXES .
8. ON CORNER LOTS, STREET TREES SHALL NOT BE PLANTED WITHIN THE AREA SPECIFIED IN SECTION 20.60 OF THE CITY CODE. THIS DISTANCE IS APPROXIMATELY 35 FEET FROM THE POINT OF INTERSECTION OF CURB LINES.
9. TREES SHALL BE IRRIGATED IMMEDIATELY UPON PLANTING AND AT LEAST WEEKLY THEREAFTER.
10. ALL STREET TREES SHALL BE INSPECTED BY A DEPARTMENT OF PUBLIC WORKS REPRESENTATIVE PRIOR TO, AND AFTER, INSTALLATION. TREES PLANTED WITHOUT PRIOR INSPECTION SHALL BE DEEMED DEFECTIVE AND SHALL BE REMOVED BY THE INSTALLER. REQUEST INSPECTION BY CALLING (408) 846-0451 FORTY-EIGHT (48) HOURS PRIOR TO PLANTING.
11. ALL WORK DONE IN THE PUBLIC RIGHT-OF-WAY SHALL BE DONE IN SUCH A MANNER AS TO AVOID CREATING HAZARDS TO THE PUBLIC. TRAFFIC CONTROL DEVICES (SIGNS, BARRICADES, FLAGMEN, ETC.) SHALL BE PROVIDED AS REQUIRED IN THE STATE "MANUAL OF TRAFFIC CONTROLS."
12. NO PERSON SHALL CONSTRUCT OR PUT IN PLACE ANY CONCRETE, BRICK, ASPHALT, WOOD PRODUCT, PLASTIC SHEETING, OR OTHER IMPERVIOUS MATERIALS TO AIR AND WATER AROUND THE BASE OF ANY STREET TREE WITHIN A DISTANCE OF THREE (3) FEET. IN ADDITION, NO EXCESS SOIL, BUILDING MATERIALS, OR DEBRIS SHALL BE PLACED ABOVE A TREE'S ROOT CROWN WITHIN A DISTANCE OF THREE (3) FEET (CITY CODE SECTION 26.15-1).
13. NO PERSON SHALL CUT, TRIM, PRUNE, SPRAY, BRACE, MOVE, REMOVE, OR REPLACE ANY STREET TREE IN THE PUBLIC RIGHT-OF-WAY WITHOUT A WRITTEN PERMIT FROM THE PUBLIC WORKS DIRECTOR (CITY CODE SECTION 26.7).

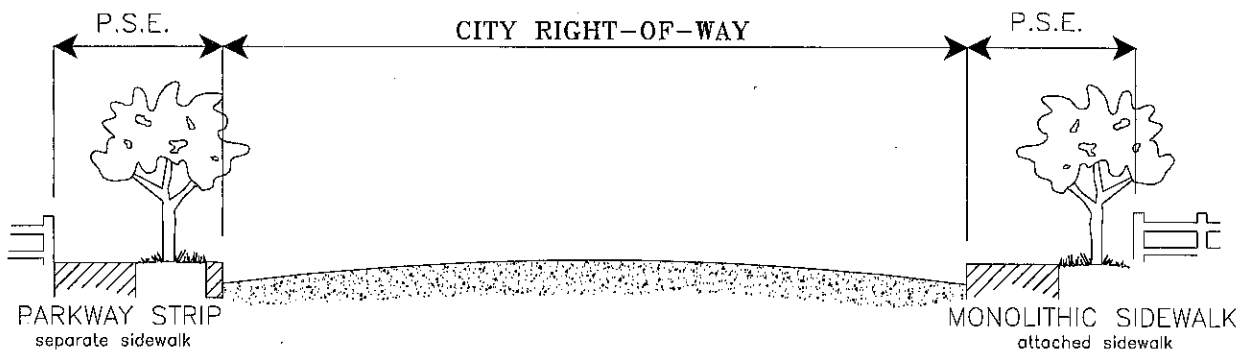

TREE PLANTING SPECIFICATIONS

DRAWN BY: CSG	SCALE:
CHECKED BY:	N.T.S.
LAST REVISED: 9/30/14	

SECTION:
LANDSCAPING

DRAWING NO.: **LS-1**



APPROVED BY:

[Signature]
CITY ENGINEER

8-18-14
DATE

← Prevailing Wind

DEEP ROOT PLANTER

#22-29-18-P (or approved equal)
 Deep Root Corp.
 15040 Golden West Circle
 Westminster, Ca. 92683
 (714) 893-0563
 (or approved equal)

One 2"x8' treated lodgepole pine stake or better on windward side.

Two 16" "Grow-Strait" tree ties (Figure 8 pattern) nailed w\ two 1 1/2" roofing nails.

Backfill with native soil (No ammendments).

Sidewalk grade

Top of rootball level to existing grade.

1/2"-1" washed gravel.

18" to 24" Root Barrier Installed 2' from center of tree

Deep root planter

Fertilizer tablets equally spaced around sides at middle of rootball (5\21 gram 20-10-5 Agriform tablets).

Compacted soil to minimize settling.

NOTES:

1. Water immediately after planting and maintain tree until accepted by inspector.
2. Manually separate roots in rootball and direct outward and down to prevent girdling of roots.
3. Orient main limbs parallel with curb and sidewalk.

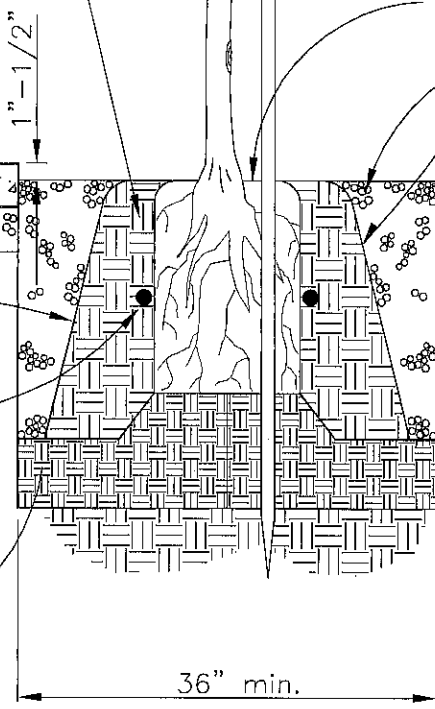

* See Standard Detail LS-1 for tree planting specifications.

FIFTEEN GALLON TREE PLANTING W/ DEEP ROOT PLANTER

DRAWN BY: CSG	SCALE:
CHECKED BY:	N.T.S.
LAST REVISED: 6/19/14	



APPROVED BY
Paul Sorenson
 CITY ENGINEER

8-18-14
 DATE

SECTION:
 LANDSCAPING

DRAWING NO.: LS-2

← Prevailing Wind

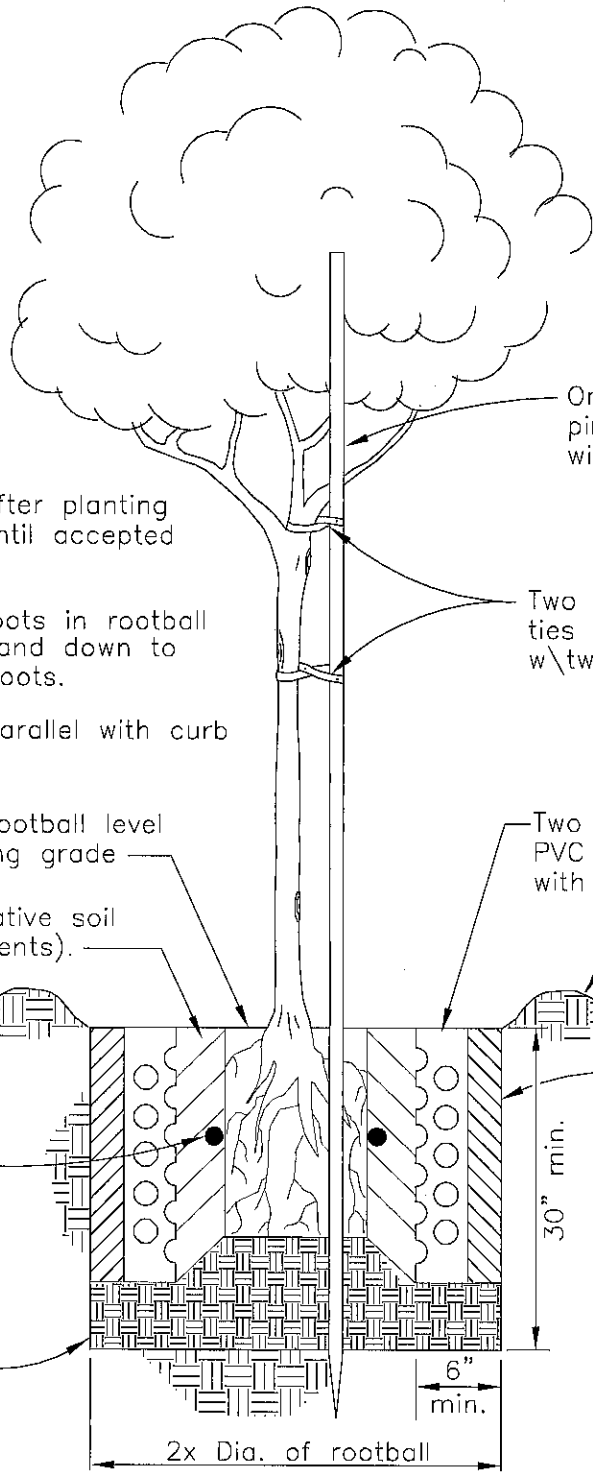

One 2"x8" treated lodgepole pine stake or better on windward side.

Two 16" "Grow-Stait" tree ties (Figure 8 pattern) nailed w\ two 1 1/2" roofing nails.

Two 4"x24" perforated PVC watering tubes filled with 1/2" washed gravel.

4" Water basin mound (where practical).

Remove clay slick from sides of hole if dug by power auger.

Install an 18" to 24" Root Barrier 2' from center of tree.

Top of rootball level to existing grade
Backfill with native soil (No ammendments).

Fertilizer tablets equally spaced around sides at middle of rootball (5\21 gram 20-10-5 Agriform tablets).

Compacted soil to minimize settling.

30" min.

6" min.

2x Dia. of rootball

NOTES:

1. Water immediately after planting and maintain tree until accepted by inspector.
2. Manually separate roots in rootball and direct outward and down to prevent girdling of roots.
3. Orient main limbs parallel with curb and sidewalk.

* See Standard Detail LS-1 for tree planting specifications.

FIFTEEN GALLON TREE PLANTING

DRAWN BY: CSG	SCALE: N.T.S.
CHECKED BY:	
LAST REVISED: 6/19/14	



APPROVED BY:
Rick Jordan
CITY ENGINEER

8-18-14
DATE

SECTION:
LANDSCAPING

DRAWING NO.: **LS-3**

SHRUB

ROOTBALL - PLANT 1" ABOVE GRADE AND THOROUGHLY SCARIFY

3" HIGH BERM

3" LAYER MULCH, PULL MULCH AWAY FROM STALK 1" TYP.

FINISH GRADE

BACKFILL MIX

PLANT TABLETS (REFER TO SPECIFICATIONS)

SCARIFY PIT WALLS

UNDISTURBED EXISTING SOIL

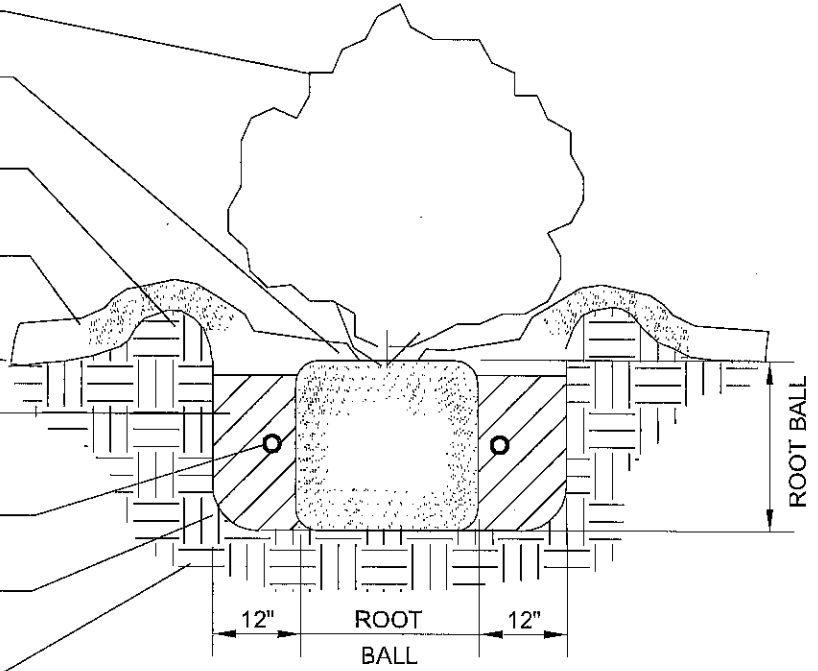

SHRUB PLANTING WITH BERM

DRAWN BY: CSG
CHECKED BY:
LAST REVISED: 6/19/14

SCALE:
N.T.S.

SECTION:
LANDSCAPING

DRAWING NO.: LS-4



APPROVED BY:
Paul Jordan
CITY ENGINEER

8-18-14
DATE

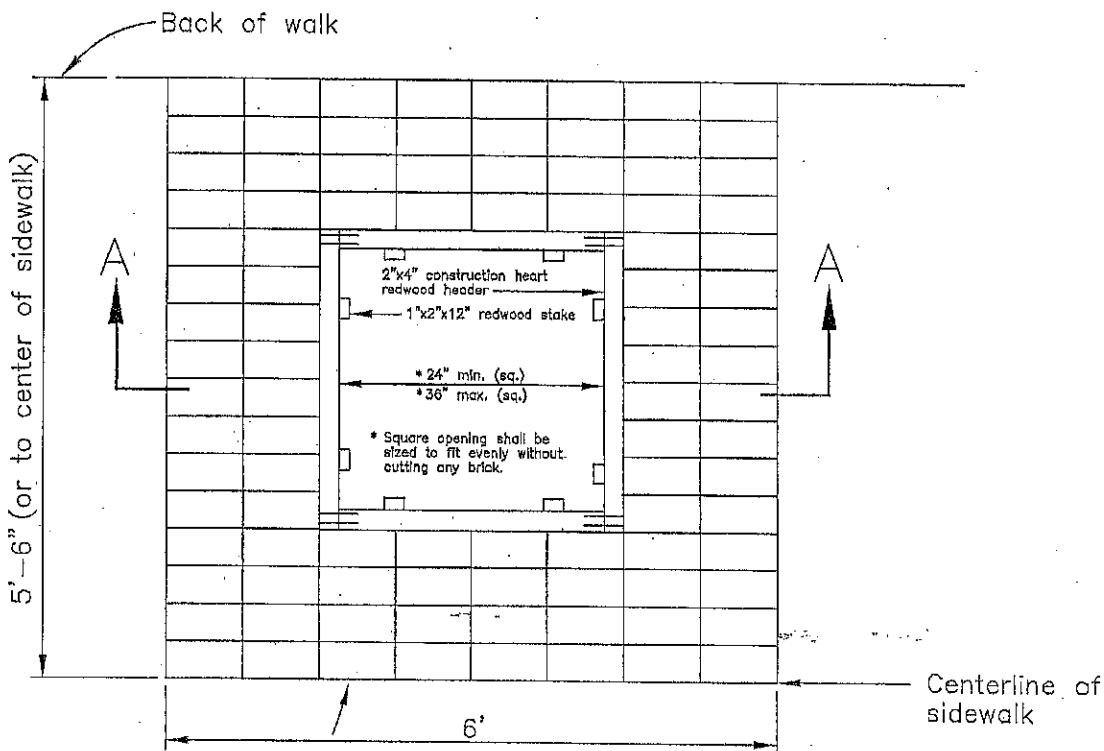

PLAN

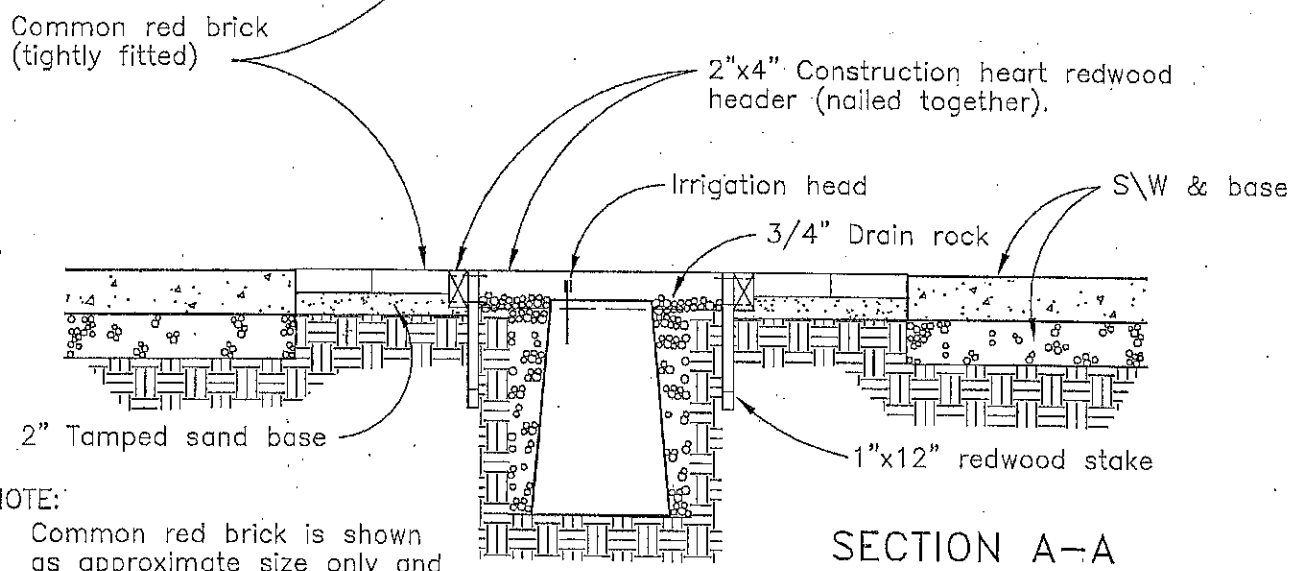

SECTION A-A

NOTE:
Common red brick is shown as approximate size only and not to true scale.

TREE WELL IN SIDEWALK

DRAWN BY: CSG	SCALE:
CHECKED BY:	N.T.S.
LAST REVISED: 6/19/14	



APPROVED BY:
[Signature]
CITY ENGINEER

8-8-14
DATE

SECTION:
LANDSCAPING

DRAWING NO.: LS-5

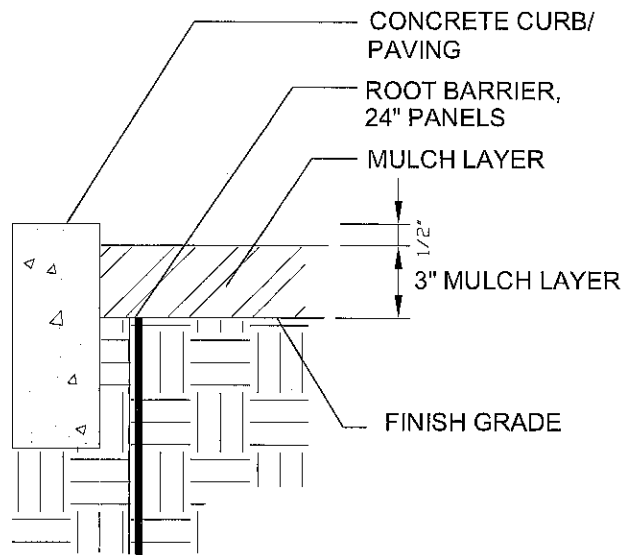

LINEAR ROOT BARRIER SECTION

NOTE:

1. LINEAR ROOT BARRIER TO BE USED IN ALL SITUATIONS WHERE HARDSCAPE IS 6' OR CLOSER TO TRUNK OF TREE
2. REFER TO TREE STAKING DETAIL

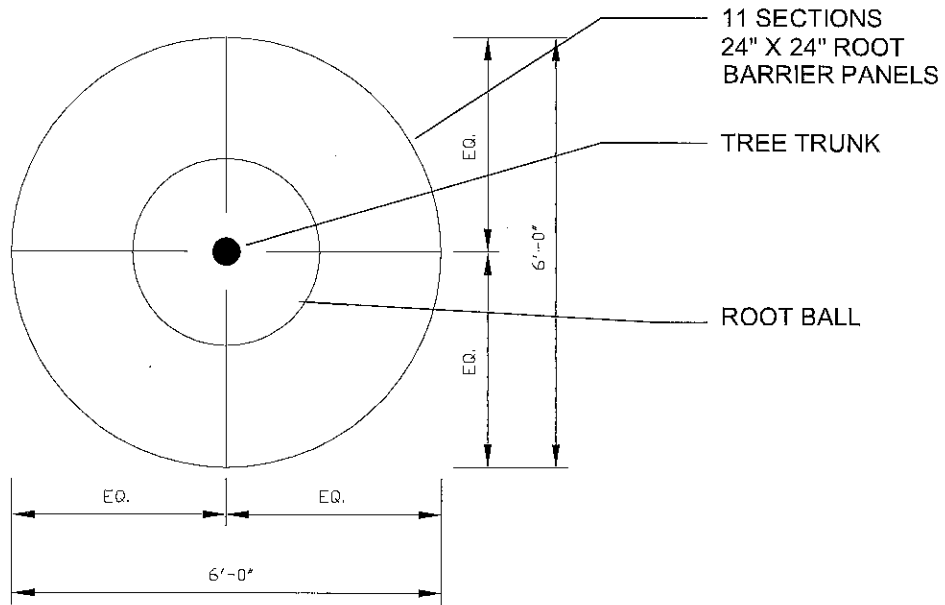

CIRCULAR ROOT BARRIER - PLAN VIEW

ROOT BARRIER

DRAWN BY: CSG
 CHECKED BY:
 LAST REVISED: 6/19/14

SCALE:
 N.T.S.



APPROVED BY:

Paul Jordan
 CITY ENGINEER
 DATE 8-18-14

SECTION:
 LANDSCAPING

DRAWING NO.: LS-6

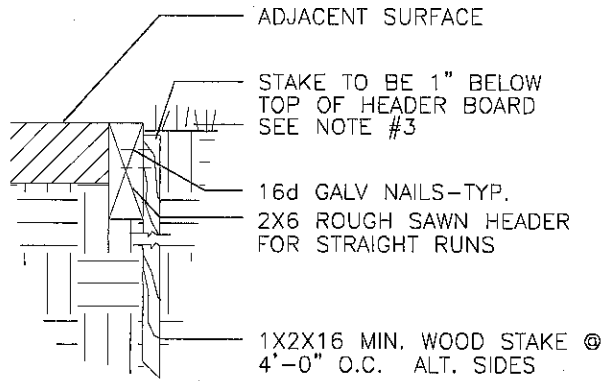

STRAIGHT SECTION

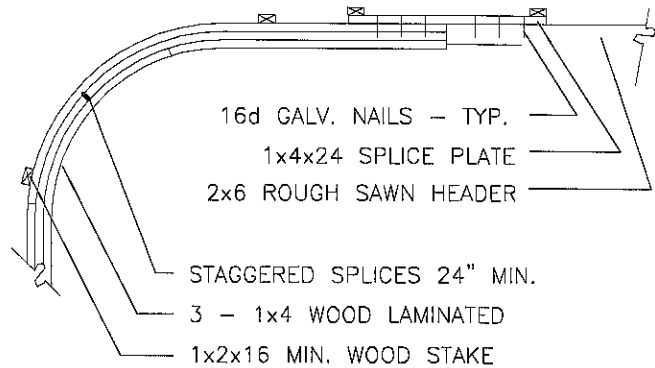

PLAN VIEW

NOTES:

1. USE CURVED DETAIL WHEN RADIUS IS LESS THAN 30' & BOARD LENGTH IS LESS THAN 16'.
2. ALL WOOD TO BE ROUGH SAWN REDWOOD CONST. GRADE.
3. FINISH GRADE OF PLANTING AREA 1" BELOW TOP OF HEADER.
4. TAPER FINISH GRADE TO 1" WITHIN 4'-0" OF HEADER BOARD.

REDWOOD HEADER BOARD

DRAWN BY: CSG	SCALE:
CHECKED BY:	N.T.S.
LAST REVISED: 6/19/14	

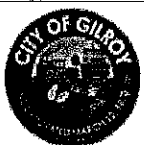

APPROVED BY:

Paul Johnson 8-18-14
CITY ENGINEER DATE

SECTION:
LANDSCAPING

DRAWING NO.: **LS-7**

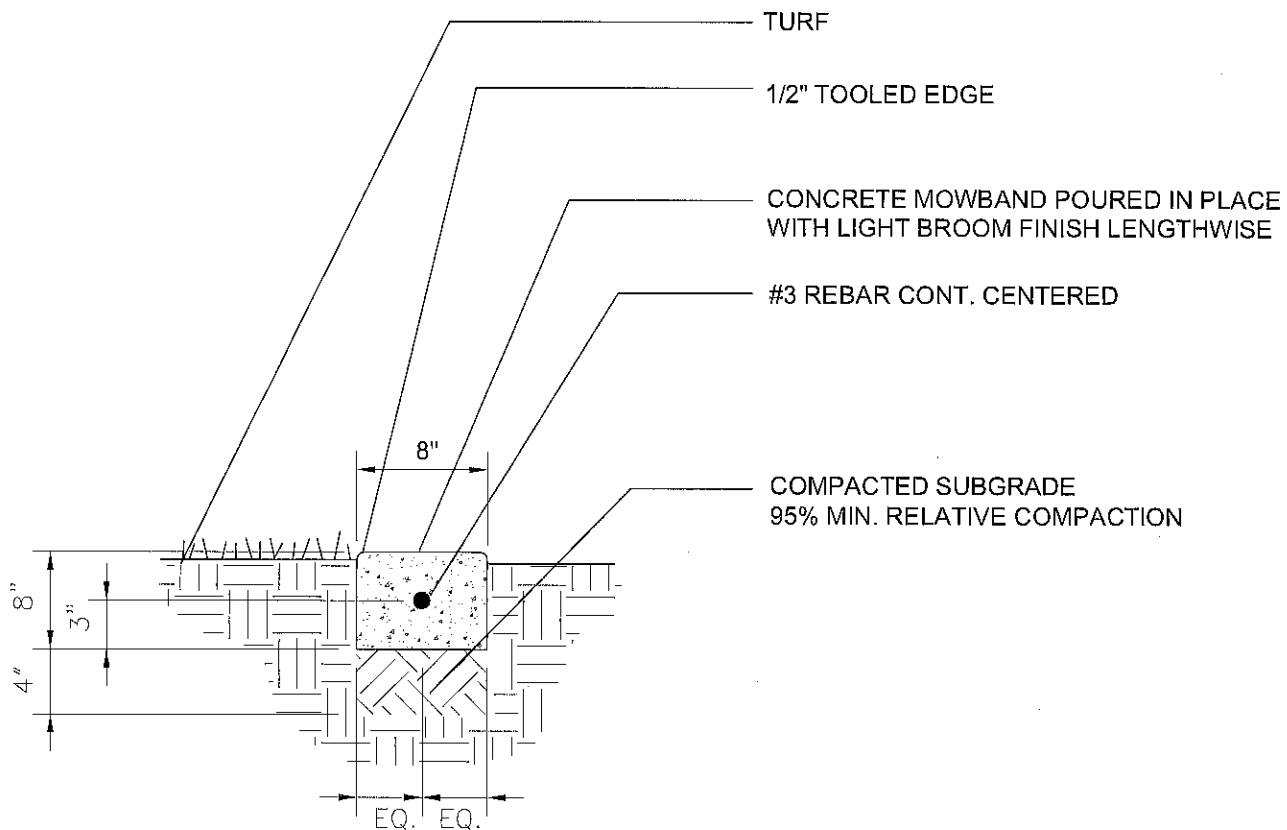

NOTE:

1. INSTALL 1/2" FELT EXPANSION JOINTS ON STRAIGHT RUNS @ 20'-0" O.C. MAX. INTERVAL AND AT 10'-0" O.C. MAX. ALONG CURVES. PROVIDE 1/8" WIDE 1/2" DEEP SCORE W/ 1/2" RADIUS TOOLED EDGE @ 5'-0" O.C. MAX. INTERVAL.
2. MOWBAND TO BE FLUSH WITH ADJACENT PAVING. MOWBAND TO BE 1" ABOVE FINISH GRADE FOR TURF. OR PLANTING AREAS.

CONCRETE 8" MOWBAND

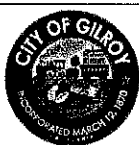

APPROVED BY:

Paul Sorensen 8-18-14

CITY ENGINEER

DATE

DRAWN BY: CSG
 CHECKED BY:
 LAST REVISED: 6/19/14

SCALE:
 N.T.S.

SECTION:
 LANDSCAPING

DRAWING NO.: LS-8

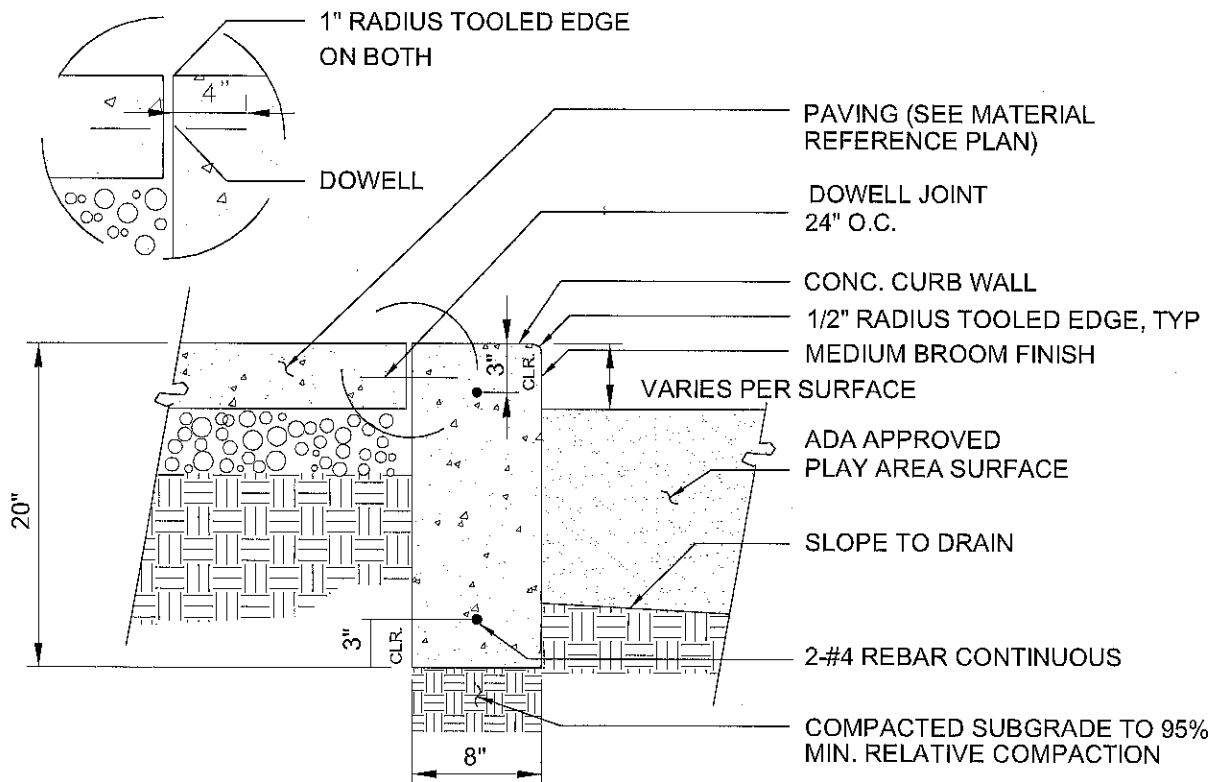

NOTE:

1. PLAY AREA SURFACE TO BE EITHER SAND, RUBBER RESILIENT PAVING, OR FIBER. REFER TO PLAY AREA PLANS, SHEET L-10.0. DEPTH FROM TOP OF CURB TO BE 4" MIN. FOR SAND. REFER TO SPECIFICATIONS.
2. AT PLAY AREA CURB - PROVIDE SCORE JOINTS 5' O.C. AND EXPANSION JOINT 15' O.C.

PLAY AREA CURB AT PAVING

DRAWN BY: CSG	SCALE:
CHECKED BY:	N.T.S.
LAST REVISED: 6/19/14	



APPROVED BY:

Rick Jordan 8-18-14
CITY ENGINEER DATE

SECTION:
LANDSCAPING

DRAWING NO.: LS-9

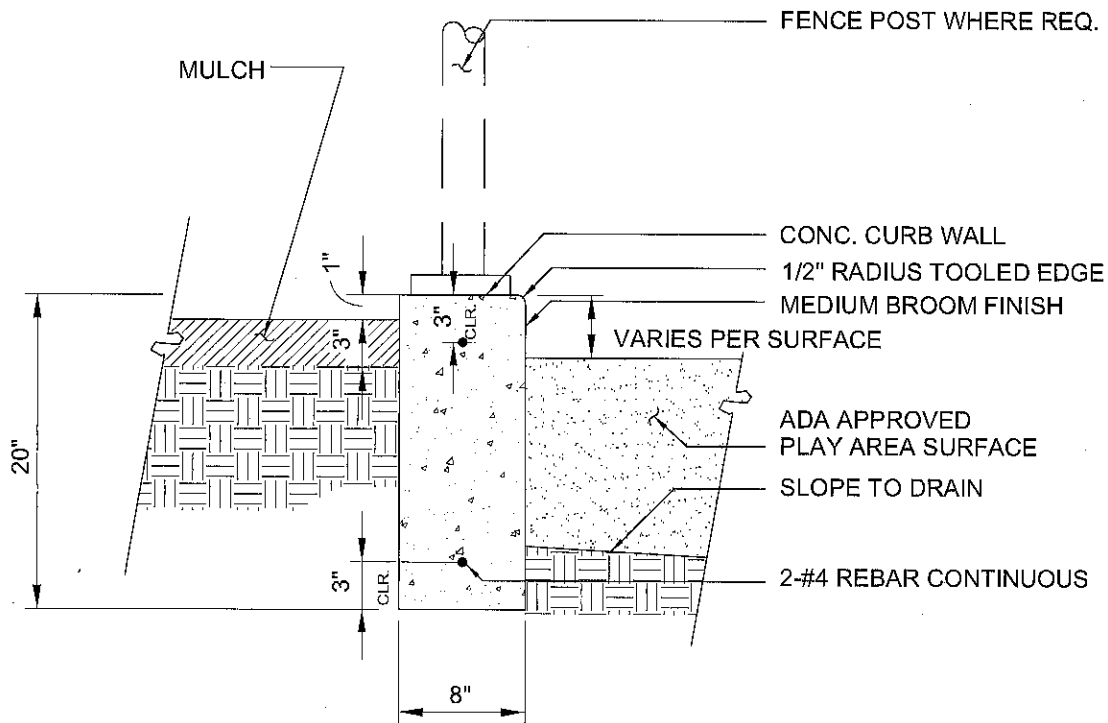

NOTE:
 PLAY AREA SURFACE TO BE EITHER SAND, RUBBER RESILIENT PAVING, OR FIBER. REFER TO PLAY AREA PLANS, SHEET L-10.0. DEPTH FROM TOP OF CURB TO BE 4" MIN. FOR SAND.

PLAY AREA CURB AT PLANTING

DRAWN BY: CSG	SCALE:
CHECKED BY:	N.T.S.
LAST REVISED: 6/19/14	



APPROVED BY:
Rick Jordan
 CITY ENGINEER

8-18-14
 DATE

SECTION:
 LANDSCAPING

DRAWING NO.: LS-10

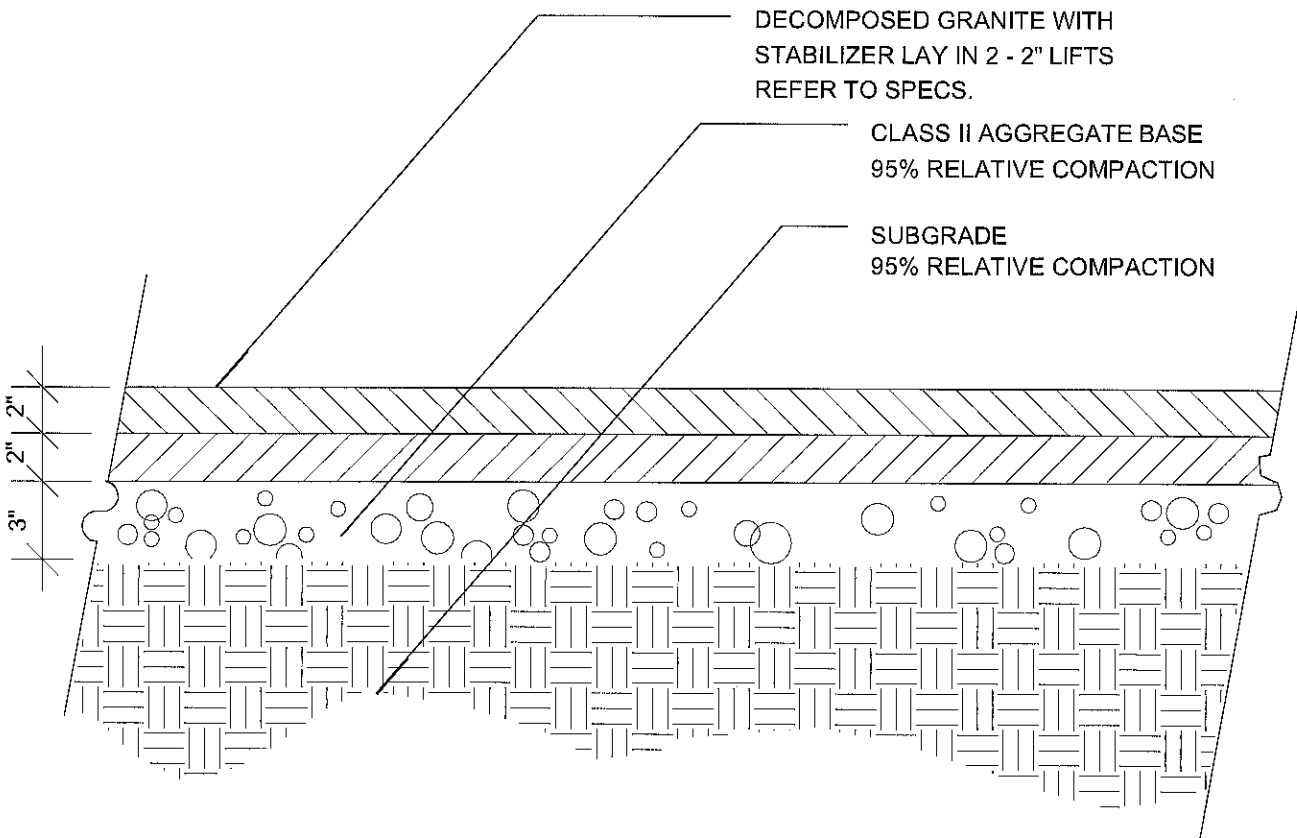

DECOMPOSED GRANITE

DRAWN BY: CSG
 CHECKED BY:
 LAST REVISED: 6/19/14

SCALE:
 N.T.S.



APPROVED BY:
Rick Jordan

CITY ENGINEER

8-18-14
 DATE

SECTION:
 LANDSCAPING

DRAWING NO.: LS-11